

# DUAL CHECK VALVE

FI

## Product Specifications

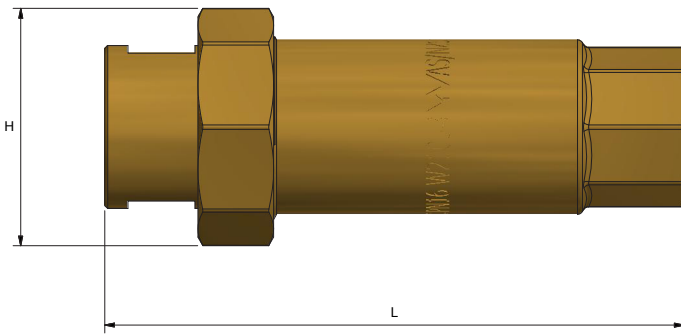

Dual Check Valves are utilised for protection from cross contamination of non potable water with potable water. They are used in low hazard conditions such as rain water tank systems and domestic meter connections.

### Specifications

Working temperature 0°C to 60°C

Maximum working pressure 1200kPa

Min. working pressure 60kPa

Not to be used on hot water installations

### Sizing Chart [MM]

	L	H
DOV15	100	41
DOV15C [CHROME]	100	41
DOV20	100	47
DOV25	103	56

### Features



Watermark approved

DR Brass

Double check valve assembly for improved flow

Compact design

Protects against back flow and back siphonage

Suitable for vertical or horizontal installations

100% factory tested for sealing operation

Tested and certified to AS/NZS 2845.1

### Material Chart

Part	Material
Bonnet	DR Brass
Washer	Fibre
Nut	DR Brass
Body	DR Brass
Check Valve	POM

For more information on Logi Valve, contact:  
Austworld 15 Activity Crescent, Molendinar, Queensland 4214 Australia  
P. 1300 780 430 F. 1300 780 441 E. [info@austworld.com.au](mailto:info@austworld.com.au)

Austworld Pty Ltd. All rights reserved 2018. Austworld and Logi Valve are registered trade mark belonging to Austworld Pty Ltd.

